LCD PC

RS-6917 All-In-One 17" LCD PC User's Guide

Version: A1.0



Users guide-Ver. A1.0
Feb, 2009

Notice

Copyright

The copyright of this user's guide belongs to any authorized company, and is protected by copyright law. This means partial or full duplication of this document (electronically, mechanically or otherwise) is prohibited without the permission of the authorized company.

The contents may be modified without notice for the improvement of design, function, and reliability.

We do not guarantee the prevention of data loss. Please be cautious not to lose important data and keep back-ups at all times.

Even though we did our best in drawing up this user's guide, there may be omissions and errors we failed to notice. Manufacturers and suppliers cannot be held liable for problems stemming from those errors and omissions.

Registered Trademark

Microsoft Windows XP is a registered trademark of Microsoft.
Intel Pentium and Celeron are registered trademarks of Intel.

Company names and product names mentioned in this document are used to help your understanding and are registered trademarks.

The permissible level (Class B) of electromagnetic waves

The product was tested for electromagnetic waves and was rated as class B, certified for sale and use worldwide.

Caution

For safe and proper installation and use of this product, please read this guide carefully.

Even though this product is equipped with a safety device to prevent users from getting injured, please follow the instructions carefully.

Caution during installation

- Install on an even and stable place to prevent product damage and injury.
- Install in a place with good ventilation to reduce humidity and to prevent overheating.
- Keep objects with magnetic properties away from this product.
- Check the operational voltage before plugging the power cord into the outlet.
- Use the power cord that is included with the product and do not place heavy things on it.
- To prevent electric shock and fire, do not use an outlet that is damaged or that is not standard.
- If you plug the power cord into an extension cord, be sure that the total voltage of all the devices connected to the cord does not exceed the number specified on it.

Caution during use

- If peripheral equipment is connected to this product, turn on the power source of the peripheral equipment first when you starting up. On the contrary, when shutting down, turn off the power source of this product first to prevent damage to the product.
- Please make sure that no liquid enters into the product. This can cause damage to the product, fire, or electric shock.
- Unplug the power cord before cleaning this product. Please

wipe with tissues or fabrics that are sprayed with a PC cleaner and do not directly spray the product.

- When this product will be idle for an extended period of time, unplug the power cord to prevent damage stemming from power surges.
- When unplugging the power cord, pull by the plug, not the wire.
- Do not place this product in a place where the temperature is over 60°C (140 °F) and ventilation is poor. This may damage the product.
- The optimum temperature for the operation of this product is 40°C, so keep electric heaters away from this product.
- Take precautions to avoid losing data stored on the hard disc of this PC and back-up important data at all times in case of an unforeseen accident.
- Do not attempt to disassemble this product. When this PC needs repairs or updates, request warranty service and have a service person do the work.
- Should the following situations occur, contact one of our quality assurance divisions.
 - ✓ When liquid gets into the product or when it is exposed to humidity for an extended time
 - ✓ When this PC does not operate well even though you are following the instructions
 - ✓ When this product has fallen and broken or become cracked during delivery.

Table of Contents

Notice	2
Copyright.....	2
Registered Trademark	2
The permissible level (Class B) of electromagnetic waves	2
Caution	3
Caution during installation	3
Caution during use.....	3
Table of Contents	5
Chapter 1. Introducing the LCD PC	7
Product features.....	7
Unpacking	8
Optional devices	8
Other peripherals	9
Preparing you LCD PC	10
Connect the AC Power Adapter.....	10
Turn ON the LCD PC.....	11
Chapter 2. Knowing the Parts	12
Front sides :	12
Rear Sides :	14
Chapter 3. Starting up the computer for the first time	15
For Windows XP	15
Step 0: Windows XP and basic driver pre-setup.....	15
Step 1: To set up the computer.....	16
Step 2: The installation of drivers for other peripherals	17
Step 3: The installation of software for other peripherals.....	18
Step 4: Completion of setup.....	18
Chapter 4. Using the computer	19
To Use Windows XP	19
Using other applications.....	20
Partitioning the hard disk	21
Chapter 5. Reinstalling the OS	22
How to reinstalling Windows XP	22
Appendix 1. Troubleshooting	24
Appendix 2. Product specifications and system diagram	27
Appendix 3. Product warranty	31

Chapter 1. Introducing the LCD PC

Product features

LCD-PC is the all-in-one PC that combines a 17" TFT-LCD monitor and a desktop computer, offering an ultra light weight of 5.8Kg and a modern design that suits any working conditions.

LCD-PC is so user-friendly that anyone can use it without difficulty because it has all major components in its all-in-one main body.

Even though the LCD-PC is very compact, its functionality is limitless. It supports out-dated and conventional peripheral devices, adapting to users' working environments. It also supports the latest peripheral devices with its four built-in USB ports (compatible with USB v2.0).

The PC enables wireless networking without additional equipment using its built-in network adaptor.

The PC's 17" TFT-LCD display, directly driven by digital signals, offers a clearer image than that of separate TFT-LCD monitor of the same class, which is driven by analog signals. Furthermore, it allows for the use of extended screens and has multi monitor functionality because it is equipped with an extension port for connecting to TVs or other external monitors.

This PC is designed to run best using Windows XP, Microsoft's latest operating system. When used with the Windows XP operating system, you can get a more stable and diverse computing environment.

The adoption of a 17" TFT-LCD monitor minimizes harmful electromagnetic waves and power consumption. Its design is engineered for the human body to minimize eyestrain.

Unpacking

This product is packaged with cardboard paper for safe delivery. If there is a defect or missing part, contact the agency where you purchased the product.

The box should contain the following items.

- ✓ 17" LCD PC main body
- ✓ 60W AC/DC power adapter
- ✓ AC power cord
- ✓ Users Guide (This document)
- ✓ Master CD (with the driver file for backup)

Optional devices

- ✓ PS-2 wheel mouse
- ✓ PS-2 keyboard
- ✓ Wireless LAN mini-pci card & Antenna (built in the main body)
- ✓ Microsoft Windows XP.

A touch screen is optional and you can order it before the product is shipped. To enable touch screen, you need to have the following device; Please carefully the touch screen if you assembly system by yourself.

- ✓ 17" Touch Screen

[For reference]

This PC has a mini-PCI slot in its main body allowing for expandability with peripheral devices that have a mini-PCI card. Our company will launch new models can support wireless LAN.

Other peripherals

This PC supports the following peripheral devices

- ✓ PS/2 Keyboard and Mouse
- ✓ Two serial communication port (RS232)
- ✓ Four USB devices (compatible with USB 2.0)
- ✓ External speakers/headphones
- ✓ External microphones
- ✓ External audio devices
- ✓ External monitors

[For reference]

- **What is USB?**

USB is a high-speed serial bus standard for the connection of peripheral devices that reduces the use of valuable system resources. Devices that support USB are USB mice, USB keyboards, USB PC cameras, USB HDDs, and USB memory sticks.

Preparing you LCD PC

These are only quick instructions for using you LCD PC.
Read the later pages for detailed information on using your LCD PC

Connect the AC Power Adapter

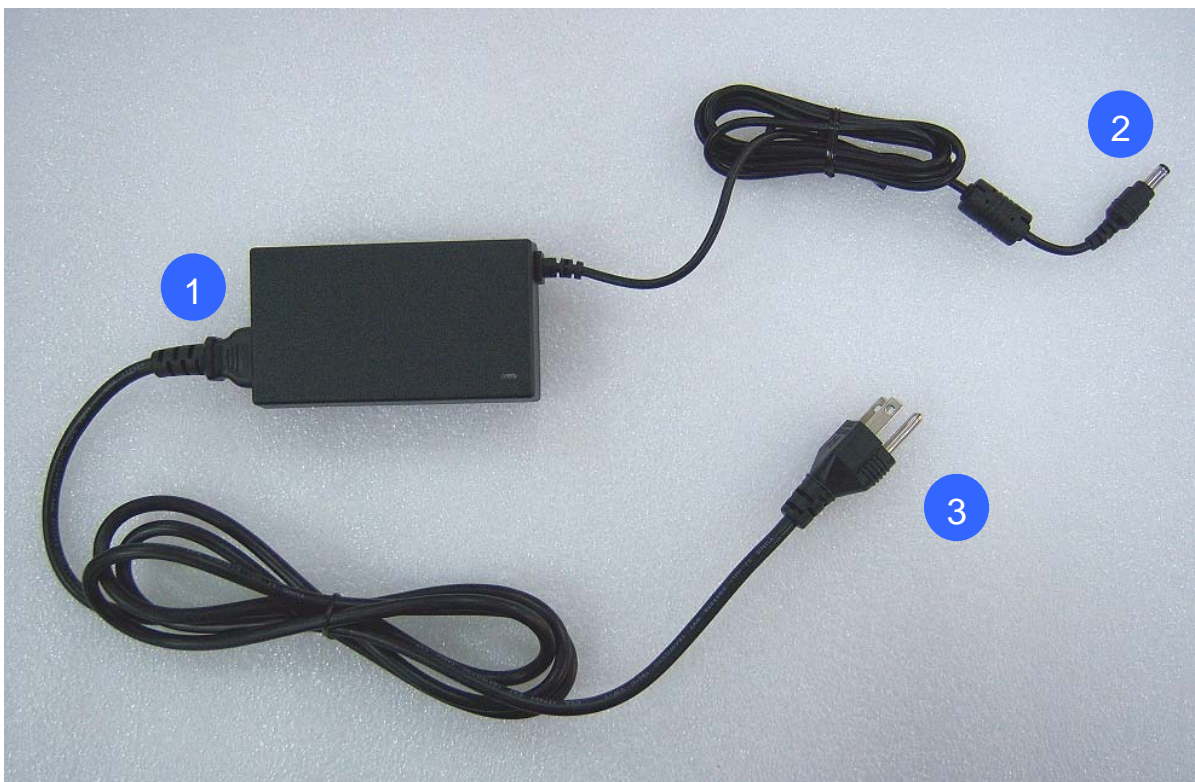

1. Insert power cord into power adapter



- 2. Insert power adapter cable into "Power Adapter Input" of rear I/O panel



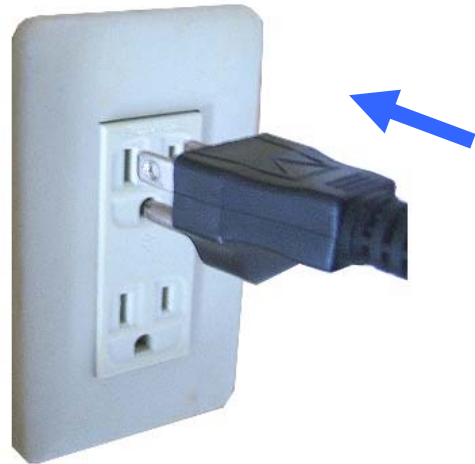

- 3. Insert power cord into AC power socket



Turn ON the LCD PC



  Power Button

LED

1. Before turn on the LED is Red color.
2. Press the power button and release.

(In Windows XP, this button can also be used to safely turn OFF the LCD PC.)

3. LED become Blue color.

Chapter 2. Knowing the Parts

Front sides :

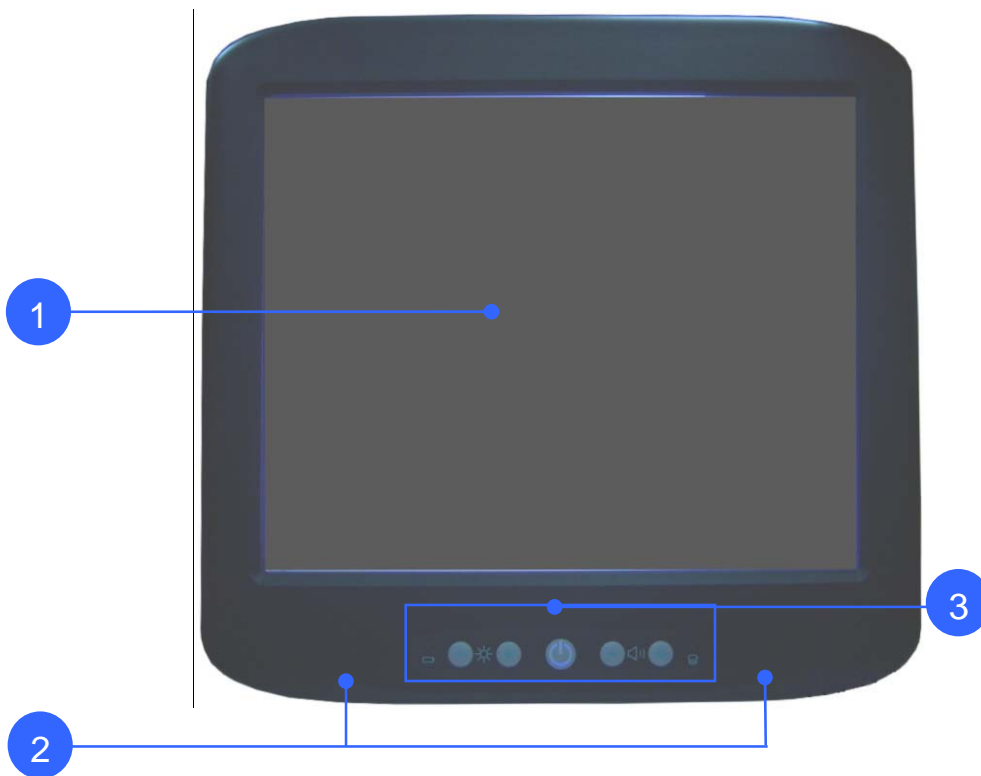

1

Display Panel

The display panel functions the same as a desktop monitor. The LCD PC uses an active matrix TFT LCD, which provides excellent viewing like that of desktop monitors. Unlike desktop monitors, the LCD panel does not produce any radiation or flickering, so it is easier on the eyes. Use a soft cloth without chemical liquids (use plain water if necessary) to clean the display panel. Pixels H x V : 1280 x 1024.

2

Audio Speaker System

The built-in stereo speaker system allows you to hear audio without additional attachments. The multimedia sound system features an integrated digital audio controller that produces rich, vibrant sound (results improved with external stereo headphones or speakers). Audio features are software controlled.

3 Instant Keys and Status Indicators



- **Power button**

 : Turns the computer on and off.

- **Buttons for adjusting the speaker volume**

 : Up(+)/Down(-) :
Adjusts the sound volume of the internal speaker.

- **Buttons for adjusting the screen brightness**

 : Up(+)/Down(-) :
Adjusts the brightness of the TFT-LCD display.

- **Status indicator lights**

 POWER : Indicates power status.

Power status	Working (G0/S0)	Sleeping (S1~S4)	Soft Off (G2/S5)	Mechanical Off (G3)
LED Color	Blue	Red	Red	Red

 HDD : Indicates the hard disc is working,
LED Color : Green.

 Battery : Indicates the charging battery is working,
LED Color : Red.

Rear Sides :

The following picture shows connectors that are for input/output connections located at the rear/side of the main body. Here we provide a brief explanation about the name and function of each connection port.

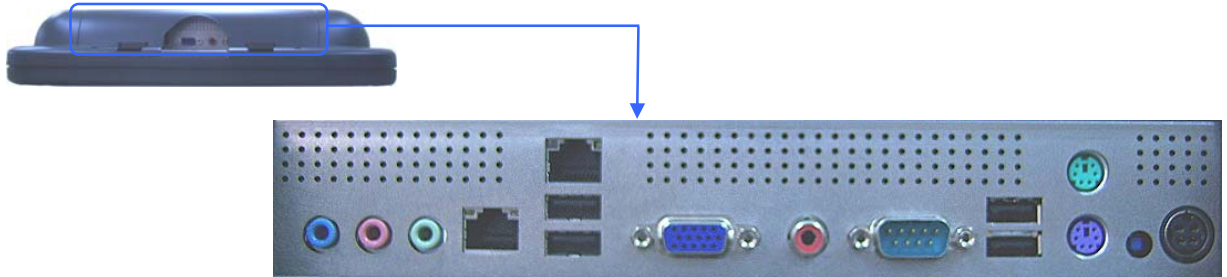

Rear I/O Panel

Rear I/O Panel	
Icon	Connections
	Power Adapter (DC) Input
	PS/2 mouse connection
	PS/2 keyboard connection
	4x USB (Universal Serial Bus) Port. USB (2.0/1.1) device connection.
	2x LAN (RJ-45) Port. 10/100 /1000 Mbps network (LAN) cable connection
	One Serial communication device connection
	Display (Monitor) Output. The 15pin D-sub monitor port support a standard VGA-compatible device such as a monitor or projector to allow viewing on a larger external display.
	External speaker or headphone connection
	External microphone device connection
	Audio input connections for external audio device connection

Chapter 3. Starting up the computer for the first time

This chapter will show you how to register a user ID for Windows and for this computer, and how to set up additional drivers and applications step by step.

For Windows XP

Step 0: Windows XP and basic driver pre-setup

This product is pre-setup with the latest driver file for Windows XP, basic specifications and other optional specifications chosen by the user before shipping.

The following is a list of operating systems and basic driver files that are pre-setup.

- Microsoft Windows XP
- VIA Video driver
- VIA Audio driver
- VIA 4 in 1 driver
- VIA SATA driver
- Marvell 88E8053 PCI Fast Ethernet NIC driver
- Microsoft DirectX
- Wireless LAN driver (option)
- Touch screen driver (option)

[For reference]

The touch screen, wireless LAN (option) must be ordered before the product is packaged and shipped. We regret to inform you that we cannot separately supply a touch screen, wireless LAN,

Step 1: To set up the computer

To set up the computer that is pre-setup with Microsoft Windows XP in step 0:

1. Connect the mouse and keyboard that come with the main body and turn on the power of the main body. The following “Microsoft Windows Start” dialog box will be displayed. To continue the setup, click <Next> at the bottom of the screen.
2. When the “User’s Time Zone” dialog box is displayed, select the proper time zone for your location and select <Next>.
3. When the “ End Users’ License Agreement” menu is displayed, select “I accept this agreement” and then click <Next>.
4. When you see the “Your Product Key” page on the screen, enter the product key specified in Windows XP user’s guide that comes with the purchase of this PC and select <Next>.
5. A dialog box will appear asking you to designate a computer name. Enter a computer name and computer description in the blanks and click <Next>.
6. A dialog box will appear asking you how you want to connect to the Internet. Select the one that best suits your connection and press <Next>. If your computer is not connected to a network or failed to establish a network connection, a dialog box with “failed to establish an Internet connection” will pop up. If you wish to set up the Internet connection later, click <Skip>. In that case, you can set up or change the network configuration at [Start]-[Control panel]-[Network and Internet connection] after you are finished installing Windows.
7. If you chose a LAN connection for accessing the Internet, a dialog box reading “High speed connection setup” will be displayed. Fill in the fields and press <Next>.

If you chose DSL or cable modem connections, the below dialog box will pop up. Follow the instructions to continue the network connection setup.

8. When you are finished with the Internet connection setup, a dialog box reading, "Are you going to receive verification service?" will be displayed. Even though you can have the verification right away to know whether your copy of Windows is licensed or not, you are recommended to select "No, not at this time." This is because it is better to activate Windows when you test the computer for a while and you are sure that there are no problems with your new PC. However, you must activate Windows within 30 days.
9. Lastly, you will see a dialog box asking who will use this computer. Enter names of users who will share the computer and press <Next>. To proceed to the next step you have to enter at least one name.
10. When a dialog box that reads "Thank you!" pops up, this means the basic setup is complete. Press <Finish> to reboot your computer and to run Windows XP.

Step 2: The installation of drivers for other peripherals

Skip this step if you do not use other peripherals.

To use other peripherals this PC supports such as printers, serial communication devices, USB devices, and game consoles/ MIDI devices, connect the device to the main body, press the power button and boot the PC. When booting is complete, install the pertinent driver in the system. Because the system automatically senses and installs plug-and-play peripherals, follow the instructions displayed on the setup menu and refer to the device's user's guide. For peripherals that are not plug-and-play, users have to install the device and reboot the system for normal operation.

Refer to the user's guide of each device for detailed instructions.

Step 3: The installation of software for other peripherals

Skip this step if you do not use other peripherals and go to step 4.

For efficient use of other peripherals (printers, serial communication devices, USB devices, and game consoles/ MIDI devices), install the appropriate software (e.g. utilities or other applications provided by the manufacturer of the device) following the instructions displayed on the setup menu and referring to the user's guide.

Step 4: Completion of setup

When you are finished with step 3, basic installation is complete and the computer is ready to use once it is rebooted.

Chapter 4. Using the computer

In this chapter, we will give a brief explanation about the use of the computer

To Use Windows XP

To use basic Microsoft Windows XP programs and applications that are available with this OS, refer to the user's guide (booklet), or the 'Help and Support Center'.

To refer to the 'Help and Support Center', click [Start]-[Help and Support] on the desktop and click on topics you need to refer to.

Microsoft Windows XP 'Help and Support Center' provides the following information on a variety of features and other basic operations of Windows XP.

- What's new in Windows XP
 - Confirmation of license and registration
 - Windows components
- Music, video, games and photos
- Windows Basics
- Networking and the Web
 - Electronic mail and the Web
 - Home network or small scale network
 - The sharing of files, printers, and other resources
 - Cipher and security
 - Networking (including Internet connection)
- Working remotely
- Designation of computer users
- Customizing your computer
- Printing and faxing
- Performance and maintenance
- Fixing a problem

- Send your feedback to Microsoft

Using other applications

To use other applications obtained or purchased separately, refer to the user's guide of each application provided by the software manufacturer.

Partitioning the hard disk

For user's convenience, the hard disk built into this product is divided into two partitions (drive C and drive D). Drive C, a system drive, is installed with a Windows operating system, a variety of drivers, and other applications when you receive the computer. In contrast, drive D, a usual data drive, is empty.

This is to let users store data in drive D to be protected in the event of a system failure. When the hard disk must be reformatted and the system must be reinstalled due to serious damage to the system, only drive C needs to be reformatted while data stored in drive D is kept intact without any intervention.

For the very first time Windows XP setup will load or recognize the devices as default C drive this is due to the build-in card reader devices. However to prevent this problem, it can be solved by following steps:

During Setup, XP will guide you to the "existing partitions and non-partitioned space on this computer" step

Search & select your Hard Drive and

1. Press "C" on the keyboard to create your hard drive partitions, usually the drive letter will be F other than C
2. Press "D" then "L" on the keyboard to delete the Hard Drive partitions you have just created
3. Press "C" on the keyboard to create your hard drive partitions again, this time the drive letter will be back to C as default drive letter.

Chapter 5. Reinstalling the OS

Should serious irreparable problems occur, users must reinstall a Windows operating system. This chapter will explain how to do that.

To reinstall the OS, you will need the Microsoft Windows installation CD and the Master CD that comes with this product. Please have these at hand before attempting to reinstall the OS.

It is important to note that users need to back up important data stored in the hard disk prior to formatting the hard disc drive and reinstalling the operating system.

How to reinstalling Windows XP

1. Insert the Windows XP installation CD into the CD-ROM drive and start up the computer. The “Windows Setup” screen will appear, automatically starting the installation.
2. Continue installing the Windows XP following the instructions displayed on the screen.
3. When installation is complete, the computer will restart running Windows XP and the desktop will appear. Insert the Master CD and wait for the automatic execution screen to appear.

Choose each driver and application from the automatic execution screen’s selection menu and install them in the following order.

- Install VIA video (required)
- Install VIA audio driver (required)
- Install VIA 4 in 1 driver (required)
- Install Marvell 88E8053 PCI Fast Ethernet NIC driver (required)
- Install VIA SATA driver (required)
- Install Microsoft DirectX (optional)
- Install Wireless Lan driver (optional)
- Install touch screen driver (essential when installing touch screen)

[Caution]

In most cases, it is necessary to restart the computer after installing drivers or utilities using the Master CD.

[For reference]

When the video driver is installed, click [Start]-[Control panel]-[Appearance and themes]-[Display] to bring up the “Display Registration Information” screen and choose the desired color quality or screen resolution from the [setting] tab. We suggest that users choose high color (16 bit) or true color (24 bit) for color quality, and 1280 X 1024 pixels for screen resolution.

Click on the [Advance] button at the lower part of the [Setup] tab to bring up the ‘basic monitor and VIA registration information’ page. On this page users can choose from among single mode, mirror mode, and multi mode under “Utility Administrator” in the [Driver Mode Setup] menu. Here, it is possible to set up an output to an external monitor.

The Marvell 88E8053 LAN driver does not need to be installed since Windows XP provides the same basic functions. However, if users want to use a variety of functions Marvell offers with the driver, it is recommended that they install it.

4. To check the status of each system device after users are finished installing the above mentioned drivers and programs, click [Start]-[Control panel]-[Performance and maintenance]-[System] to bring up the [Hardware] screen in ‘System registration information’. Here click ‘Device administrator’ to check whether each device is working properly. If the yellow exclamation mark is in front of the device’s name or if the name of the device is not displayed, this means the pertinent device is not functioning normally or it is not properly installed. In this case, users have to update or reinstall the driver for that device.

Appendix 1. Troubleshooting

The table below is an outline of general problems that may occur during the use of the PC along with suggested solutions. If any of these problems should occur, proceed with the instructions in the table below or refer to the 'Troubleshooting' topic in Windows' online 'Help'. If the problem persists or if problem descriptions do not describe your problem, contact one of our sales agency or the Customer Support Center.

Table. Trouble shooting

Problem	Countermeasure
Error message reading 'Operating system not found' appears when booting.	Check if the BIOS setup utility properly reads the hard disk. If it turns out that the hard disk is not being read properly, contact the Customer Support Center.
Error message 'CMOS checksum error' appears when booting.	This can occur when the motherboard's CMOS backup batteries have run out. Contact the Customer Support Center to replace the batteries.
Booting to safety mode.	<ol style="list-style-type: none"> 1. This can be caused when the computer was not properly shut down. Click [Start]-[End] to shut off the computer and reboot. 2. This may stem from the failure to read the system environment. Click and execute [Start]-[Program]-[Sub program]-[System tool]-[Disk inspection] and reboot the computer. 3. This may occur when there is a problem with a system device. Click [Start]-[Control panel]-[Performance and maintenance]-[System] and select 'device administrator' under the hardware tab. If you find a problem with a certain device, reinstall the device.

The monitor appears blank or the screen is too dark.	Adjust the screen contrast using the buttons on the front panel of the computer monitor. Should problems persist, contact the Customer Support Center.
Mouse is not working.	<ol style="list-style-type: none"> 1. Check if the mouse is properly connected to the PS/2 port located at the rear of the monitor. The USB cable must be connected to the USB port. 2. This can occur when there is a problem with the mouse device administrator. Click [Start]-[Control panel]-[Performance and maintenance]-[System] and then click on [Device administrator]-[Mouse and other pointing devices] in 'hardware' tab. Remove the mouse item and restart the computer.
Keyboard is not working.	<ol style="list-style-type: none"> 1. Check if the keyboard is properly connected to the PS/2 port located at the rear of the monitor. The USB type must be connected to the USB port. 2. When the system is down, this may occur. Restart the computer and check whether the keyboard is working.
USB device is not working.	<ol style="list-style-type: none"> 1. If the USB device manufacturer provides the driver, install the driver first and restart the computer. 2. Disconnect the USB device and then reconnect it and check if it works properly. (Re-execute the plug-and-play functionality) 3. This may be caused if the system fails to read the USB device or USB device administrator, restart the computer and check if it works properly. 4. To check if there is the problem with the USB device, try connecting it to another computer. If it works fine with the other computer, contact the Customer Support Center.
Unable to shut off the computer.	This could stem from a number of reasons. First, turn off the computer by pressing the power button for more than four seconds. If this does not work, unplug

	<p>the power cord. If you turn on the computer this time, 'scan disc' will automatically be carried out. If this symptom should repeat, contact the Customer Support Center.</p>
<p>The computer suddenly freezes while in use.</p>	<ol style="list-style-type: none">1. This may be caused by an error in a program. Press <Ctrl>+<Alt>+ and click on 'End now' on the [Windows Task Manager] dialog box.2. This can be caused by an error in Windows. Restart the computer by pressing the power button for more than four seconds.

Appendix 2. Product specifications and system diagram

HARDWARE

CPU

- VIA Eden ULV Processor : 1.6GHz. Processor :

Chipset

- VIA VX800

System Memory

- So-DIMM x 2 (up to 4GB)
- DDRII 667/533MHz

System BIOS

- Award BIOS : ACPI 1.0b & USB Booting Support

Display

- Built-in 17" TFT-LCD Display Monitor (1280x1024, LVDS Interface)
- VIA Chrome9 HC3 DX9 IGP (share memory up to 64/128/256MB).
- CRT (support 1920x1440 resolution).

Audio

- Realtek ALC888 6-channel HD Audio.

Storage

- HDD : 2.5" size, SATA (up to 500GB)
- CF Socket : For Compact Flash card.
- Integrated Slim CD-ROM drive:
Optional DVD-ROM & Combo(DVD & CD-RW) drive optional.

Input / Output / Peripherals

- PS/2 Keyboard and Mouse port
- Two Serial RS-232 ports
- Microphone in / Speaker out / Line in
- Two RJ-45 Ethernet connector
- Four USB port (USB v2.0 compliant, four internal USB jumper pin)
- One VGA Out
- Touch screen (optional)
- One TV cable In.

NETWORKING & COMMUNICATION**Networking**

- TCP/IP, 10/100/1000 Base-T Fast Ethernet
- Built-in Ethernet Controller: Marvell 88E8053

SOFTWARE**Operating System**

- Microsoft Windows XP.

BIOS Utility Program

- Hardware monitoring utility (CPU Temperature & Voltage, Fan Speed, System voltage)

ENVIRONMENTAL**Environmental Specifications**

- Operating temperature 5° to 35°C
- Storage temperature 0° to 60°C
- Humidity 30% to 80% non-condensing

Power Specifications

- AC to DC adapter
- 100-240 VAC at 50-60Hz
- Max 55W

REGULATORY COMPLIANCE

EMC / Safety

- CE
- FCC

PHYSICAL CHARACTERISTICS

- Weight: 5.8 kg (Main Body only)
- Length: 414 mm
- Width: 393 mm
- Depth : 820 mm

WARRANTY

- 1 year warranty standard

MODEL CONFIGURATION

Model	CPU	DDR SDRAM / HDD	ODD / OS

SYSTEM BLOCK DIAGRAM

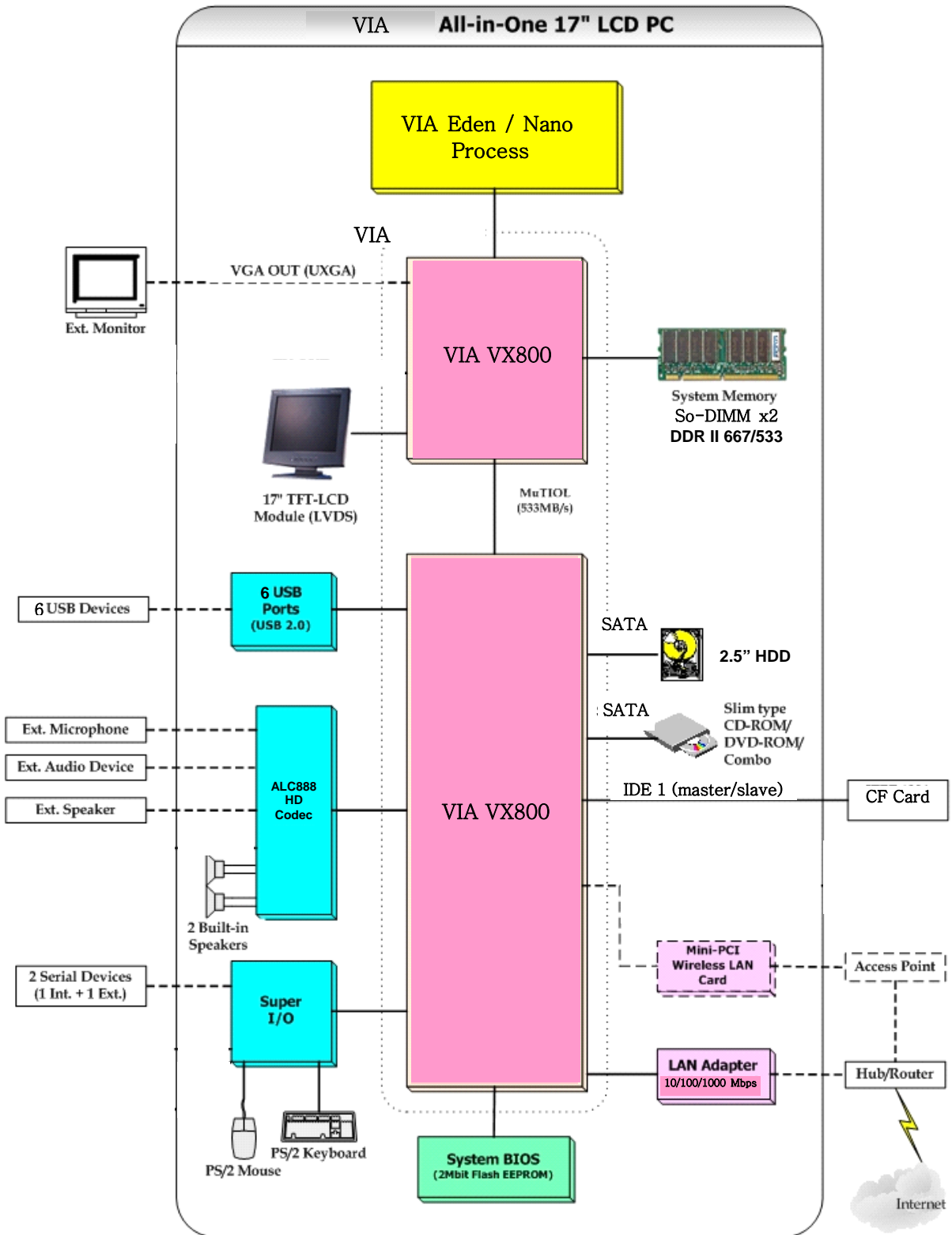

Appendix 3. Product warranty

About the product warranty

1. Keep the product warranty document and complete it with the necessary information when you make the purchase.
2. We do our best to provide the best quality assurance.
3. Even within the warranty period, charges can be applied for those services, which are charge-based.
4. We do not make compensation for all the dependent losses due to trouble of the product.
5. In order to kept safety and stability of equipment do not adjust stand fixed.
6. If our label removed the warranty is void.

Product warranty

We guarantee as follows.

- 1) This product is manufactured with strict quality assurance and inspections
- 2) The free warranty service period is one year from the date of purchase.
- 3) When requesting repair, please show the warranty document to the service representative.
- 4) We do not reissue warranty documents, so keep them with care.
- 5) Contact the agency from which you made the purchase if there is problem with this PC. If it is something that cannot be handled by the agency, contact our Customer Support Center to ask for technical support. This way, your needs will be looked after appropriately.

Charge-based service

The following services are charge-based.

- Malfunction or damage to the product due to careless handling by the user.
- Problems caused by software
- Damage caused by natural disaster
- Damage or changes to the product that is done by people other than our service representative.
- Problems resulting from trouble with the power source

Recommendations and caution

- 1) Position this product away from direct sunlight or magnetic waves. If those factors are unavoidable, find ways to protect the product.
- 2) Please equip with (A.V.R) or (Power Conditioner) with enough capacity for a stable operation.
- 3) If users do not have the warranty document or have not completed the warranty document, they can receive free or charge-based warranty services according to the guidelines specified in the Consumer Protection Law.

Model Name
(RS-6917-XXXXXXXX)